

# AGGRELITE



Developed from our proven muck shifting range, this specially designed steel body is low in weight to maximise payload of sand, aggregates, roadstone and quarry products up to 75mm diameter.

This is a high performance, robust and durable steel body that benefits from a monocoque design to compete directly with traditional aluminium bodies, to offer light body weight with long life.

*High payload – long life*



Model illustrated includes optional lights

[www.boweld.co.uk](http://www.boweld.co.uk)

*... taking the weight off your fleet*

# AGGRELITE

# AGGRELITE

## Construction

- CAD aided Monocoque weight saving design
- All floor pans pressed from wear resisting steels to 400HBW
- All body sections pressed from high yield steels
- Fully jig built to exacting tolerances
- Fully seam welded after fabrication
- Tailgate formed from wear resisting steels
- Side panel designed to incorporate lower integral strengthening beam
- Boweld 'P' Type high strength double pivot tailgate hinges
- Segmented curved cab guard
- High strength rear cross member and back posts

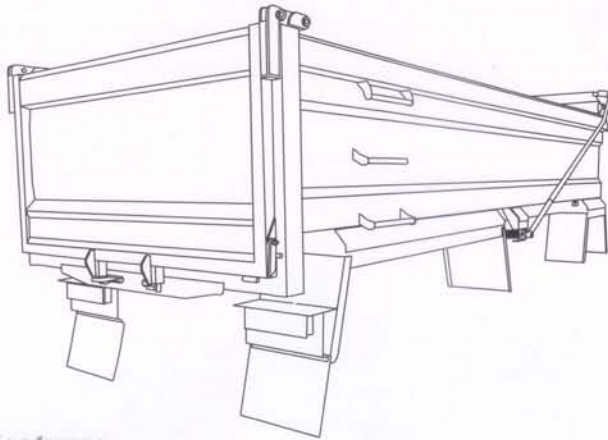

## Features

- Unique one piece pressed side panel design
- Wiring run through integral side strengthening beam for protection.
- Greaseable, machined swivel pins in tailgate hinges
- Full 'bolt on' mudguard kits
- Mudguards laser cut to guarantee easy retro fit
- Twin longitudinal floor pans with formed rigid centre bracing
- Load cradle floor design for extra strength
- Safety 'hold open' tailgate stay
- Load inspection step and hand rail
- Hydrogen controlled seam welds using MIG/MAG welding process
- Easy to clean, paint and sign write sides and tailgate
- Anti stick slope between floor and sides
- Anti stick slope along inner base of headboard
- Unrivalled payload in its class

## Options

- Body built ready to accept PROCOVER sheet system
- Body built ready to accept AIRCLAW tailgate system
- Bolt on rear push bar
- Choice of 3.5mm & 5.5mm floor thickness
- Meshed cab guard view panel
- Full access ladder
- Choice of body heights
- Choice of tailgate hinges
- Aluminium spat capping
- FLEXIGATE combination door system
- Hockey stick hinges

## Construction

Boweld tipper bodies are purpose designed to utilise a range of high performance steels, specially selected by Boweld for their strength, durability and wear resistance. All bodies are manufactured in a modern purpose built factory using the latest production techniques from steel body components laser cut for precision and to prevent stress. Bodies are continuous seam welded using MIG welding (low hydrogen for improved weld reliability and strength) in dedicated body jigs to ensure body alignment, accuracy and reliability.

## Flexible Specification



Select your ideal body depth with Bowelds slide and set top channel and side arrangement variable on the AGGRELITE between 1060mm and 1600mm (15 to 23 cubic metres). This haulage company has specified the very versatile FLEXIGATE combination tail gate and barn door to enable him to expand his work duties, the FLEXIGATE is fitted in conjunction with the AIRCLAW automatic tail gate opening system.



Triple access bars, aluminium mudguard spat capping, full bolt on mudguard kit and Boweld 'P' hinge assemblies with grease tech swivel pins complete the requested options. The floor is a centre braced load cradle design (floor pan is pressed up to meet the side panel) this strengthens the rear lower corner of back post to prevent cracking. The AGGRELITE body is available with a choice of floor thickness to gain maximum payload, see options panel to spec yours!



## Quality

Boweld bodies are renowned for their durability and quality. Bodies are purpose designed and manufactured to comply with the highest quality standards. All bodies are fully guaranteed (see warranty leaflet) for 3 years

## BOWELD Truck Bodies Ltd

Pentre Halkyn . Nr. Holywell . Flintshire CH8 8JP . United Kingdom  
T +44 (0)1352 781566 . F +44 (0)1352 781141 . E info@boweld.co.uk

[www.boweld.co.uk](http://www.boweld.co.uk)

