

ECO LITE



A single skinned general purpose steel body, equally suitable for muck shifting or general aggregate haulage. A proven body that is often specified as a high performance and cost effective replacement body.

*Payload and strength
...at an affordable price*



Model illustrated includes optional items

www.boweld.co.uk

... taking the weight off your fleet

ECOLITE

ECOLITE

Construction

- Fully jig constructed
- Fully seam welded
- Boweld 'P' Type high strength double pivot tailgate hinges
- High strength wear plate floor to 400HBW
- Unique one piece mono profile single skin side design
- Side design incorporating weld free top channel
- Sides pressed from 4mm thick S355 steel
- High strength smooth designed tailgate
- Tailgate pressed from 4mm thick S355 steel
- One piece pressed steel cab guard

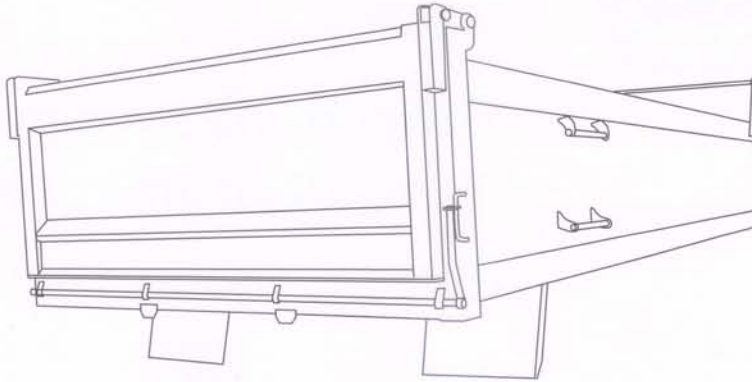

Features

- Sides designed flat for easy cleaning and sign writing
- Greaseable, machined swivel pins in tailgate hinges
- Full 'bolt on' mudguard kits
- Mudguards laser cut to guarantee easy retro fit
- Replacement mudguards available ex-stock
- Safety 'hold open' tailgate stay
- Shovel holder
- Load inspection step and hand rail
- Anti stick plates fitted to base of sides and headboard
- Monocoque design, easy to paint and maintain

Options

- Body built ready to accept PROCOVER sheet system
- Body built ready to accept AIRCLAW tailgate system
- Full access ladder
- Rear push bar
- Rope hooks
- Meshed cab guard view panel
- Choice of body heights
- Aluminium spat capping
- FLEXIGATE combination door system
- Hockey stick hinges

Construction

Boweld tipper bodies are purpose designed to utilise a range of high performance steels, specially selected by Boweld for their strength, durability and wear resistance. All bodies are manufactured in a modern purpose built factory using the latest production techniques from steel body components laser cut for precision and to prevent stress. Bodies are continuous seam welded using MIG welding (low hydrogen for improved weld reliability and strength) in dedicated body jigs to ensure body alignment, accuracy and reliability.

Flexible Specification



Mono profile side which incorporates the top channel to make for a really smooth weld-free side structure. Customer specified hockey stick Hinge assembly for wide aperture tail gate opening. The body depth is variable but limited to between 950 and 1000mm. Our experience over many years has shown this to be the optimum height area for muck shift.



One piece pressed cab guard to enhance the smooth mono profile weld free side design. Full bolt on mudguard kit, shovel rack and a customer specified PROCOVER front to rear sheet system. Boweld 'P' type double pivot tail gate hinge's can be fitted as shown below as can any of the operator beneficial product range shown in the options list.



Quality

Boweld bodies are renowned for their durability and quality. Bodies are purpose designed and manufactured to comply with the highest quality standards. All bodies are fully guaranteed (see warranty leaflet) for 3 years

BOWELD Truck Bodies Ltd

Pentre Halkyn . Nr. Holywell . Flintshire CH8 8JP . United Kingdom
T +44 (0)1352 781566 . F +44 (0)1352 781141 . E info@boweld.co.uk

www.boweld.co.uk

